

סדרות

1. השלימי.



קפיצות של 2



קפיצות של 5



קפיצות של 10

2. הקיפי את המספר הבא בסולם.

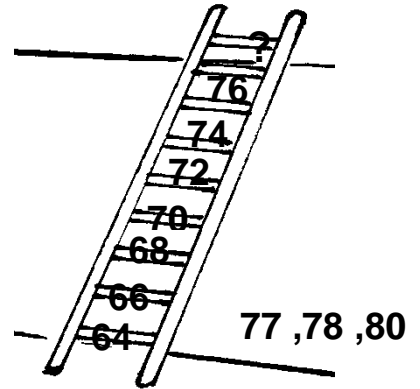
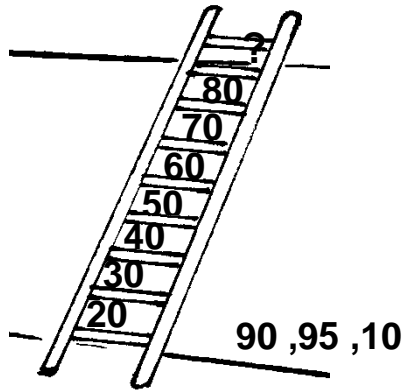
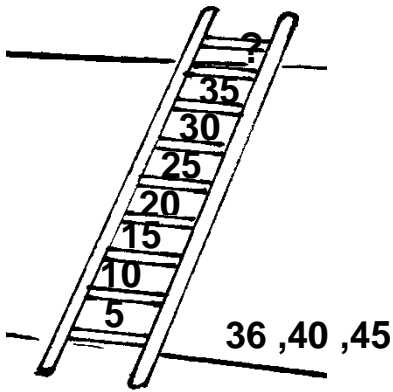

3. בכמה קפצתי?



קפצתי ב _____



קפצתי ב _____



קפצתי ב _____